

# *PFE700SA Series*

## *Instruction Manual*

### **BEFORE USING THE POWER SUPPLY UNIT**

Be sure to read this instruction manual thoroughly before using this product. Pay attention to all cautions and warnings before using this product. Incorrect usage could lead to an electrical shock, damage to the unit or a fire hazard.

#### **⚠ DANGER**

Never use this product in locations where flammable gas or ignitable substances are present. There are risks of igniting these substances and exploding by an arcing.

#### **⚠ WARNING**

- Do not touch this product or its internal components while circuit is live, or shortly after shut down. There may be high voltage or high temperature present and you may receive an electric shock or burn.
- While this product is operating, keep your hands and face away from it as you may be injured by an unexpected situation.
- Do not make unauthorized changes to this product, otherwise you may receive an electric shock and void your warranty.
- Do not drop or insert anything into the product. It might lead to a failure, fire and electric shock.
- Do not use this product under unusual condition such as emission of smoke or abnormal smell and sound etc. It might lead fire and electric shock, In such cases, please contact us. Do not attempt repair by yourself, as it is dangerous for the user.
- Do not operate these products in the presence of condensation. It might lead to fire and electric shock.

#### **⚠ CAUTION**

- This power supply is designed and manufactured for use within an end product such that it is accessible to SERVICE ENGINEERS only.
- Confirm connections to input/output terminals and signal terminals are correct as indicated in the instruction manual before switching on.
- Input voltage, Output current, Output power, ambient temperature, base-plate temperature and ambient humidity should be kept within specifications, otherwise the product will be damaged.
- Do not operate and store this product in an environment where condensation might occur. In such case, waterproof treatment is necessary.
- The equipment has been evaluated for use in a Pollution Degree 2 environment.
- Do not use this product in environment with a strong electromagnetic field, corrosive gas or conductive substances.
- For application which requires very high reliability (Nuclear related equipment, medical equipment, traffic control equipment, etc.), It is necessary to provide a fail-safe mechanism in the end equipment.
- Do not inject abnormal voltages into the output terminal or signal terminal of this product. The injection of reverse voltage or over voltage exceeding nominal output voltage into the output terminal or signal terminal might cause damage to internal components.
- Never operate the product under overcurrent or short circuit conditions. Insulation failure, or other damages may occur.
- The output voltage of this power supply unit is considered to be a hazardous energy level (The voltage is 2V or more and the electric power is 240VA or more). It must not be made accessible to users. Protection must be provided for Service Engineers against indirect contact with the output terminals and/or to prevent tools being dropped across them. While working on this product, the AC input power must be switched off and the input, output, +BC, -BC and R terminal voltage should be safe level.
- The application circuits and their parameters are for reference only. Be sure to verify effectiveness of these circuits and their parameters before finalizing the circuit design.
- Use a Fast-Blow external fuse to each module to ensure safe operation and compliance with the safety standards to which it is approved. The recommended input fuse rating within the instructions is as follows: 15A, 250V fast acting fuse. The breaking capacity and voltage rating of this fuse may be subject to the end use application.

**⚠ CAUTION**

- This model is considered non-SELV. End equipment manufacturers must provide protection against inadvertent contact by a Service Engineers.
- This information in this document is subject to change without prior notice. Please refer to the latest version of the data sheet, etc., for the most up-to date specifications of the product.
- No part of this document may be copied or reproduced in any form without prior written consent TDK-Lambda.

**Note : CE MARKING**

CE Marking when applied to a product covered by this handbook indicates compliance with the low voltage directive (2006/95/EC) in that it complies with EN60950-1.



### 3. Block Diagram

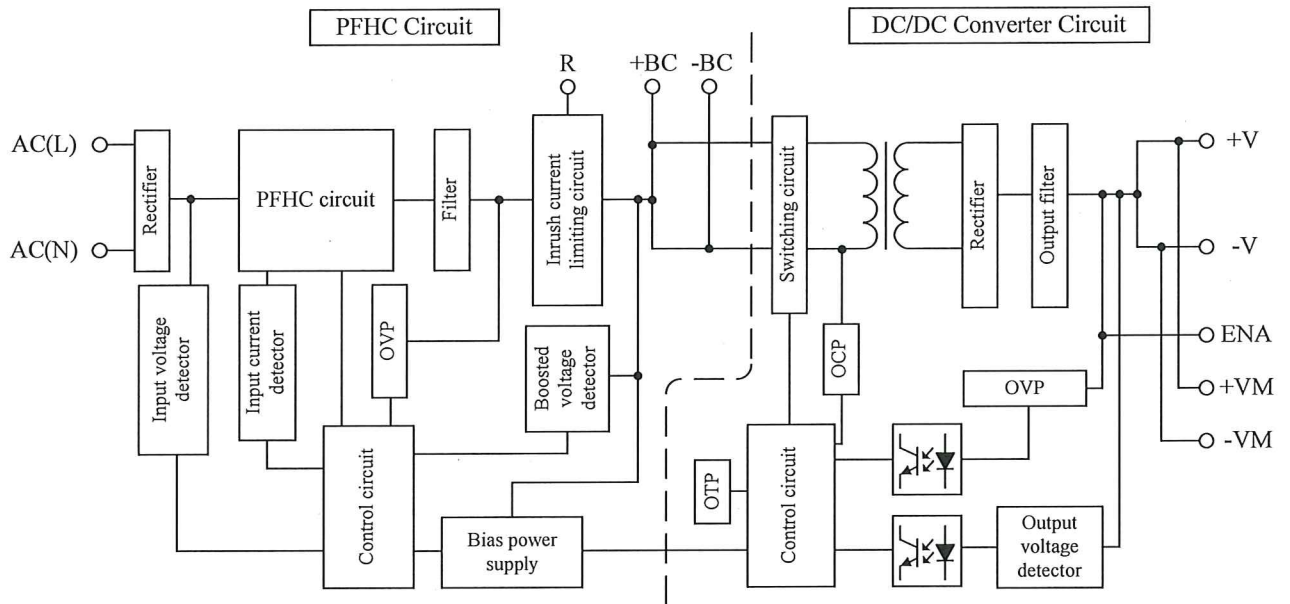

Switching Frequency

PFHC Circuit (fixed) : 100kHz

DC/DC Converter Circuit (fixed) : 180kHz (primary), 360kHz (secondary)

### 4. Sequence Time Chart

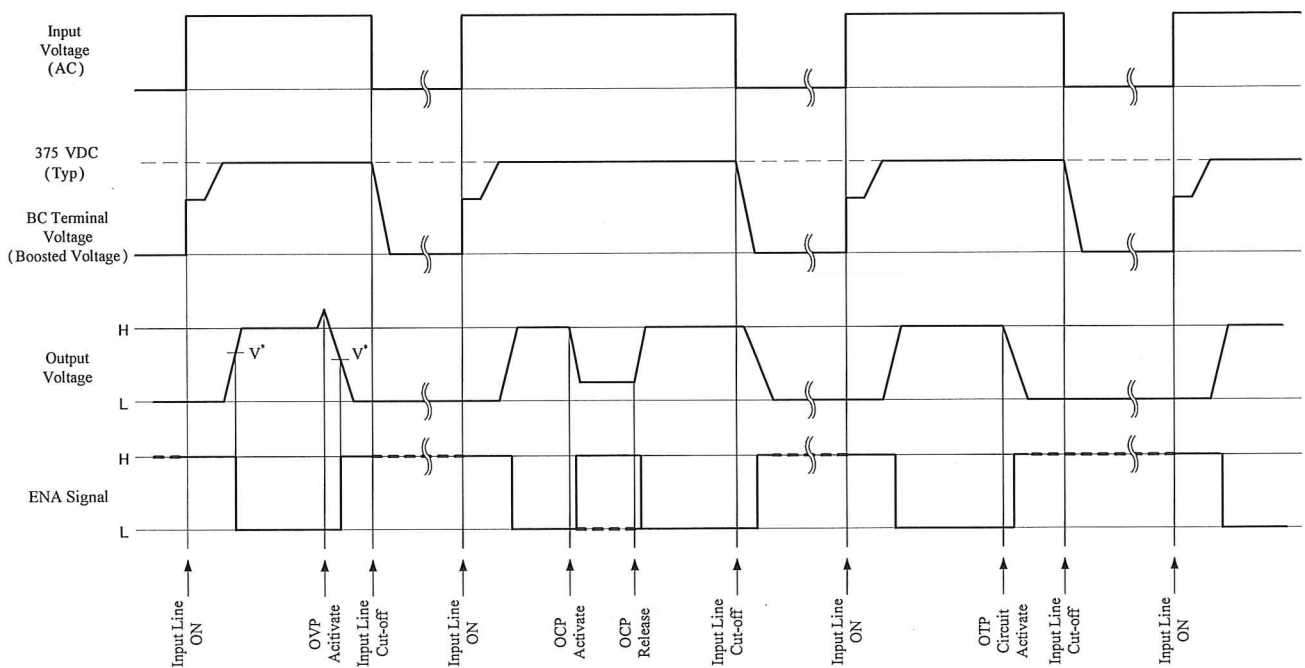

Note : This product has no remote ON/OFF function.

V\* voltage level: Refer to Application Notes "6-6.Power ON Signal (ENA Terminal)" section.

### 5. Terminal connecting method

In order to use the PFE700SA Series, this module must be connected with external components according to Fig.5-1.

Pay attention to the each wiring. If it is connected to wrong terminal, the power supply will be damaged. PFE700SA Series employs conduction cooling method. Use heat sink and fan to dissipate heat.

For selection of heat sink and heat sink dissipation method, refer to the Power Module Application Note.

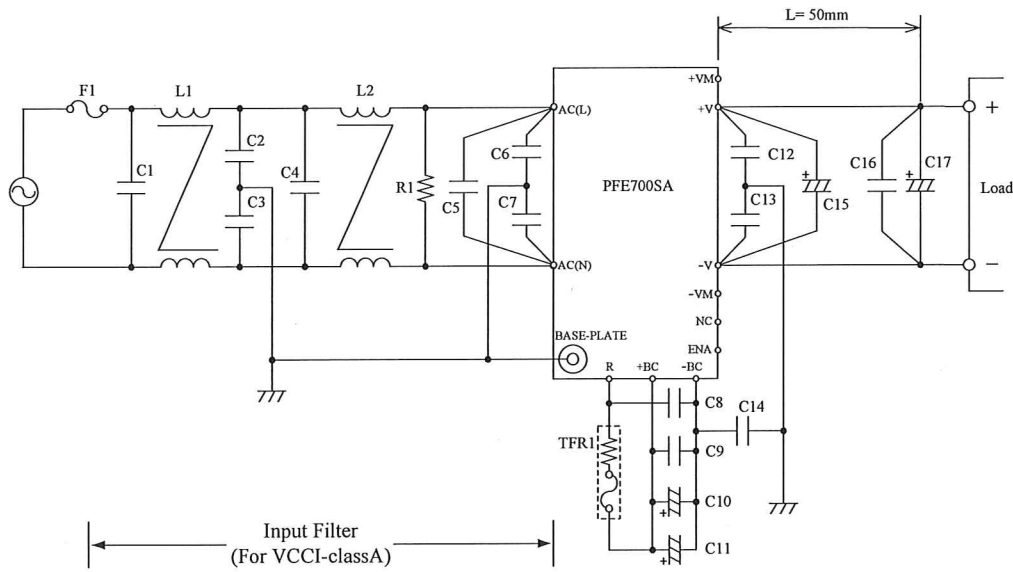

Fig.5-1 Basic connection

**F1 : External Input Fuse**

PFE700SA Series has no internal fuse. Use external fuse to acquire each Safety Standard and to further improve safety. PFE700SA Series acquired safety standard certification using 15A, 250V, Fast-Blow external fuse. Further, Fast-Blow type fuse must be used per one module. Also, in-rush surge current flows during line throw-in. Be sure to check I<sup>2</sup>t rating of external switch and external fuse.

Recommended External Fuse : 15A , 250V

Note) Select fuse based on rated voltage, rated current and surge current capability.

(1) Voltage Ratings

100VAC line : AC125V

200VAC line : AC250V

(2) Current Ratings

Rated current is determined by the maximum input current based on operating conditions and can be calculated by the following formula.

$$I_{in}(\max) = \frac{P_{out}}{V_{in} \times \eta \times PF} \text{ (Arms) (Formula 5-1)}$$

I<sub>in</sub> (max) : Maximum Input Current

P<sub>out</sub> : Maximum Output Power

V<sub>in</sub> : Minimum Input Voltage

η : Efficiency

PF : Power Factor

For Efficiency and Power Factor values, refer to separate document “PFE700SA Evaluation Data”.

**C1, C4, C5 : 1uF (Film Capacitor)**

Ripple current flows through this capacitor. When selecting capacitor, be sure to check the allowable maximum ripple current rating of this capacitor. Verify the actual ripple current flowing through this capacitor by doing actual measurement.

Connect C5 as close as possible towards the input terminals AC(N) and AC(L) of this power module.

Recommended Voltage Rating : 250VAC

**L1, L2 : 6mH**

Add common mode choke coil as EMI/EMS countermeasure. When using multiple modules, connect coil to each module.

Note) Depending on the input filter used, noise might increase or power module might malfunction due to filter resonance.

**C2, C3 : 4700pF(Ceramic Capacitor)**

Add ceramic capacitor as EMI/EMS countermeasure. Be sure to consider leakage current of your equipment when adding this capacitor.

High withstand voltage are applied across this capacitor depending on the application. Select capacitor with high withstand voltage rating.

**R1 : 470k $\Omega$**

Connect bleeder resistor across AC(L) and AC(N) terminals.

**C6, C7 : 1000pF(Ceramic Capacitor)**

Add ceramic capacitor as EMI/EMS countermeasure. Be sure to consider leakage current of your equipment when adding this capacitor.

High withstand voltage are applied across these capacitor during withstand voltage test depending on the application. Select capacitors with high withstand voltage rating.

Connect C6 as close as possible to AC(N) terminal, C7 as close as possible to AC(L) terminal.

**C8, C9 : 1uF(Film Capacitor)**

Ripple current flows through this capacitor. When selecting capacitor, be sure to check the allowable maximum ripple current rating of this capacitor. Verify the actual ripple current flowing through this capacitor by doing actual measurement.

Connect C8 as close as possible to R terminal and -BC terminal, C9 as close as possible to +BC terminal and -BC terminal.

Recommended Voltage Rating : 450VDC

Note) Select Capacitor with more than 3A (rms) rating.

**C10, C11 : 390uF(Electrolytic Capacitor)**

Refer to "Selection Method of External Bulk Capacitor for Boost Voltage" below. Allowable external capacitance at nominal capacitance value is shown below.

Recommended Voltage Rating : 450VDC

Recommended Total Capacitance : 390uF - 1200uF

- Note)
1. Do not connect capacitors with more than the above capacitance value as this would result into power module damage.
  2. When using module below -20°C ambient temperature, AC ripple of boost voltage, output ripple voltage might be affected by ESR characteristics of the bulk capacitors. Therefore, be sure to verify characteristics by actual evaluation.

**C12, C13 : 0.033uF**

Connect ceramic or film capacitor as EMI/EMS countermeasure and to reduce spike noise.

High withstand voltage is applied across this capacitor during withstand voltage test depending on the application.

Connect C12 as close as possible to +V terminal, C13 as close as possible to -V terminal.

**C14 : 1000pF(Ceramic Capacitor)**

Add ceramic capacitor as EMI/EMS countermeasure.

High withstand voltage are applied across this capacitor during withstand voltage test depending on the application. Select capacitors with high withstand voltage rating.

Connect C14 as close as possible to -BC terminal.

**C15: 220uF(Electrolytic Capacitor)**

To reduce output ripple noise voltage, connect electrolytic capacitors across +V and -V.  
Connect C15 as close as possible to the +V and -V output terminals of this power module.

Recommended Voltage Rating : 100VDC

**C16: 2.2uF(Ceramic Capacitor)**

Connect chip ceramic capacitor at 50mm from the output terminals +V and -V of the power module to reduce output spike noise.  
Also, note that output spike voltage may vary depending on the wiring pattern of the printed circuit board.

**C17 : 220uF(Electrolytic Capacitor)**

Connect C17 at 50mm from the output terminals +V and -V of the power module to stabilize operation.  
Note that the output ripple and line turn off characteristics of the power module might be affected by the ESR and ESL of the electrolytic capacitor.  
Also, note that output ripple voltage may vary depending on the wiring pattern of the printed circuit board.  
Sudden change in output voltage due to sudden load change or sudden input voltage change can be reduced by increasing external output capacitance value.

Recommended Voltage Rating : 100VDC

- Note)
1. Use low-impedance electrolytic capacitors with excellent temperature characteristics.  
(Nichicon PM Series or equivalent)
  2. For module operation at ambient temperature  $-20^{\circ}\text{C}$  or less, output ripple voltage might be affected by ESR characteristics of the electrolytic capacitors. Increase the capacitance values shown below.

C15,C17:  $100\text{V } 220\mu\text{F} \times 2$  parallel (Ambient Temperature  $\leq -20^{\circ}\text{C}$ )

3. Take note of the maximum allowable ripple current of the electrolytic capacitor used. Especially, for sudden load current changes, verify actual ripple current and make sure that allowable maximum ripple current is not be exceeded.

For connection other than recommended capacitance, be sure to verify characteristics by actual evaluation.



● **Selection Method of External Bulk Capacitor for Boost Voltage**

Boost voltage bulk capacitor is determined by boost voltage ripple voltage, ripple current and hold-up time. Select capacitor value such that boost voltage ripple voltage does not exceed 15Vp-p.

Note) When ambient temperature is -20°C or less, ripple voltage of boost voltage might increase due to ESR characteristics. Therefore, verify above characteristics by actual evaluation.

For output hold-up time, refer to separate document “PFE700SA Evaluation Data” and use appropriate capacitor up to 1200uF maximum. It is recommended that verification should be done through actual evaluation.

For allowable ripple current value, refer to Fig.5-2 and select a capacitor with higher ripple current rating.

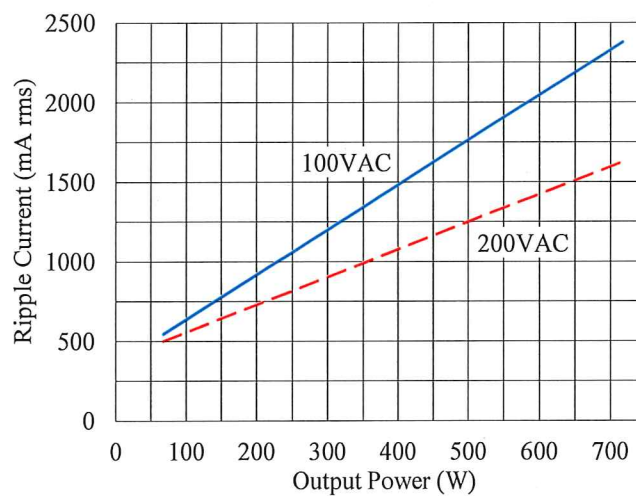

Fig. 5-2 Allowable ripple current value

The recommended boost voltage bulk capacitance value range is 390uF-1200uF.

When using with reduced the bulk capacitance value, it is necessary to reduce output power as shown in Fig. 5-3.

Fig. 5-3 shows recommended value at 25°C Base-plate Temperature (Tbp). Temperature variance might have some effect on the characteristics. Therefore, verify characteristics by performing actual evaluation. Refer to “Fig. 7-1 Base-plate Measuring Point”.

Note that reducing the bulk capacitance affects output hold-up time, dynamic line response and dynamic load response characteristics. It is recommended that verification should be done through actual evaluation.

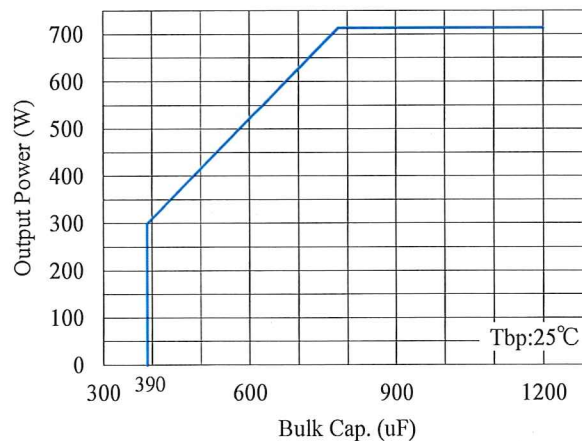

Fig. 5-3 Output Power v.s. Boost Voltage Bulk Capacitance

**TFR1 : 10Ω - 100Ω**

By connecting thermal fuse resistor across R and +BC terminals as shown in Fig. 5-1, in-rush current during line throw-in can be suppressed. Failures due to in-rush current such as melting of external fuse, welding of relay or switch connecting joints or shutdown of No-Fuse Breakers (NFB) can occur. Therefore, be sure to connect this external thermal fuse resistor of 10Ω or more. The allowable resistance value is limited by the external bulk capacitance value of shown in fig.5-4. Note that power supply will not operate if this external resistor is not connected.

**●Selection Method of External Resistor**

(1) Calculating Resistance Value for External TFR1

Resistance can be calculated by the formula below.

$$R = \frac{V_{in}}{I_{rush}} (\Omega) \quad (\text{Formula 5-2})$$

- R : Resistance Value for External TFR1
- V<sub>in</sub> : Input Voltage converted to DC value = Input Voltage (rms) × √2
- I<sub>rush</sub> : Input surge current value

(2) Required Surge Current Rating

Sufficient surge current withstand capability is required for external TFR1. Required Surge Current Rating can be selected by I<sup>2</sup>t. (Current squared multiplied by time)

$$I^2t = \frac{C_o \times V_{in}^2}{2 \times R} (A^2s) \quad (\text{Formula 5-3})$$

- I<sup>2</sup>t : Current-squared multiplied by time
- C<sub>o</sub> : Boost Voltage Bulk Capacitance
- V<sub>in</sub> : Input Voltage converted to DC value = Input Voltage (rms) × √2
- R : Resistance Value for External TFR1

(3) Resistance limitation Value for External TFR1

External TFR1 is limited as shown in drawing below. Drawing below shows resistor value at 25°C Base-plate Temperature. Input Surge current might vary due to temperature. Therefore, verify characteristics by performing actual evaluation.

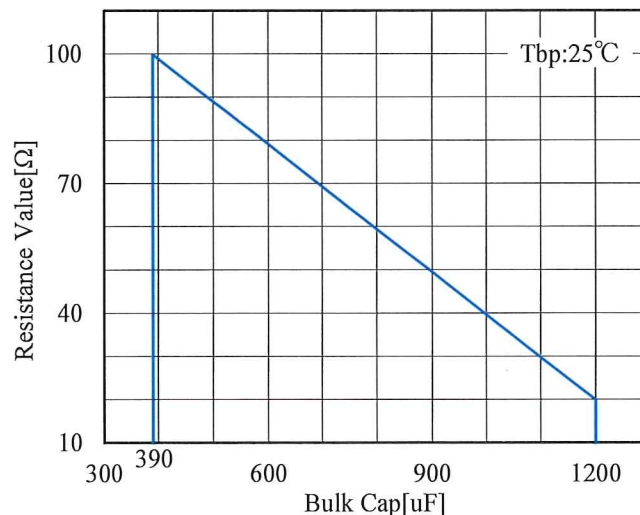

Fig.5-4 Resistance Value v.s. Boost Voltage Bulk Capacitance

## **6. Explanation of Functions and Precautions**

### **6-1. Input Voltage**

Input voltage range is single phase 85-265VAC(47-63Hz). Take care not to apply input voltage which is out specified range nor should a DC input voltage be applied as this would result into power supply damage.

For cases where conformance to various safeties required, described as 100-240VAC (50-60Hz)

### **6-2. Inrush Current**

Input surge current changes with the thermal fuse resistor (TFR1) value and external boost voltage bulk capacitance value (C10, C11).

It is recommended that verification should be done through actual evaluation.

The inrush current value indicated in the specification is measured under 25°C using basic connection.

Inrush current increases after recovery from short interruptions.

Please be careful in the selection of an input switch, an external fuse, etc.

### **6-3. Over Voltage Protection (OVP)**

This module is equipped with OVP function. OVP function operates within 60V-69.6V. When OVP triggers, the output will be shut down.

When the OVP function activates, first cut off input line and verify that boost voltage has dropped down to 7V or less. Then, recover output by recycling input line.

OVP value is fixed and cannot be set externally. Pay attention not to apply higher voltage externally to the output terminal to avoid power supply damage.

### **6-4. Over Current Protection (OCP)**

This module is equipped with OCP function. OCP function operates when the output current exceeds 105% of maximum DC output current of specification.

Output will automatically recover when short circuit or overload condition is removed. OCP value is fixed and cannot be adjusted externally.

Note that continuous short circuit or overload condition might result in power supply damage.

### **6-5. Over Temperature Protection (OTP)**

This module is equipped with OTP function. This function will activate and shut down the output when ambient temperature or internal temperature abnormally rises. OTP activates at following Base-plate temperature.

OTP operate temperature : 105°C - 130°C

When OTP function operates, output can be recovered by cooling down the baseplate sufficiently and letting the boost voltage drop down to 7V or less before recycling the input line.

### **6-6. Power ON Signal (ENA Terminal)**

This signal is located at the secondary side (output side) and an open drain output.

Maximum sink current : 10mA

Maximum applied voltage : 75V

Return line for ENA terminal is the -V terminal.

When output voltage goes over 45V(TYP) at start up, Power ON Signal is "Low level".

### 6-7. Maximum Ripple and Noise

This value is measured according to the description below in accordance with JEITA RC-9131B.

In the basic connection shown in Fig. 5-1, additional connection shown in Fig. 6-1 is done for measurement. Capacitor (Ceramic Capacitor : 2.2 $\mu$ F and Electrolytic Capacitor : 220 $\mu$ F) must be connected within 50mm from the output terminals. Then, connect coaxial cable with JEITA attachment across the ceramic capacitor electrodes. Use 100MHz bandwidth oscilloscope or equivalent.

Also, note that output ripple voltage and output spike noise may vary depending on the wiring pattern of the printed circuit board.

In general, output ripple voltage and output spike noise can be reduced by increasing external capacitor value.

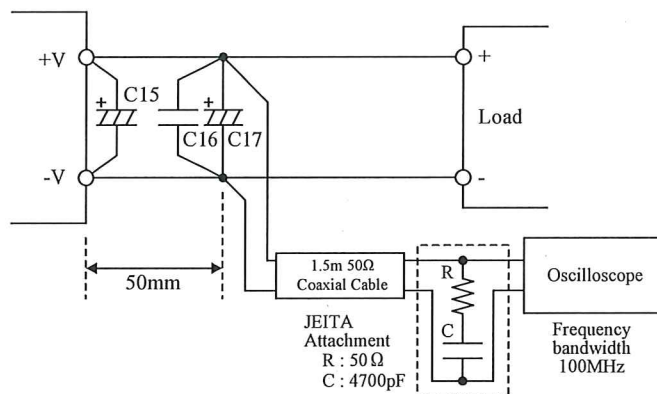

Fig.6-1 Output Ripple Voltage (including Spike Noise) Measurement Method

### 6-8. Parallel Operation

Output current sharing through parallel operation is possible for PFE700SA Series by connecting the output terminal.

For maximum output current at parallel operation, use within 85% of the rated output current.

In order to evenly split the load current, wiring impedance should be the same for each module from output terminals up to the junction point of each power supply. Perform actual evaluation to ensure that output current of each module does not exceed their own rated output current.

Also, maximum allowable modules in parallel are 5 pieces.

Consult us for details when using PFE700SA Series at parallel operation.

### 6-9. Series Operation

Series operation is possible for PFE700SA Series. Connections shown in Fig.6-2 and Fig.6-3 are possible.

Also, Maximum allowable modules in series are 3 pieces.

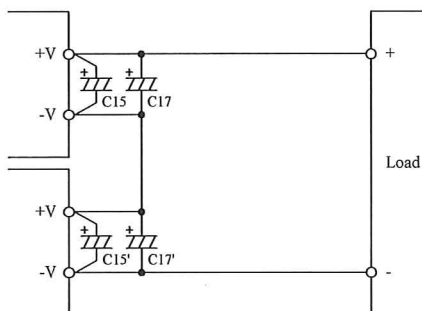

Fig.6-2 Series Operation (High Output Voltage Applications)

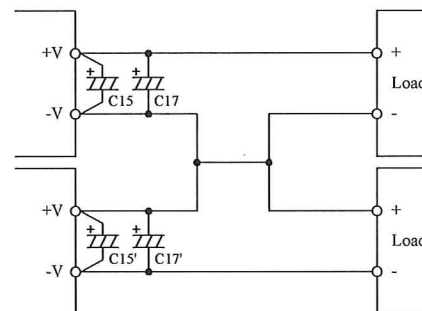

Fig.6-3 Series Operation (+/-Output Series Applications)

### 6-10. Isolation Resistance

Isolation resistance between Output – Base-plate is more than  $100M\Omega$  at 500VDC. For safety operation, voltage setting of DC isolation tester must be done before the test. Ensure that the unit is fully discharged after the test.

Output – Base-plate :  $100M\Omega$  or more at 500VDC

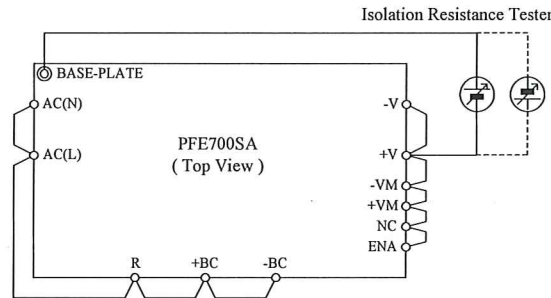

Fig.6-4 Isolation Resistance Test Method

### 6-11. Withstand Voltage Test

This series is designed to withstand 2.5kVAC between input and base-plate, 3.0kVAC between input and output and 1.5kVDC between output and base-plate each for 1 minute.

When performing tests at Input – base-plate and Input – Output, do the withstand voltage test after setting current limit value of the withstand voltage testing equipment to 20mA.

Be sure to apply DC voltage between Output - base-plate. Avoid applying AC voltage during this test because this will damage the power supply.

The applied voltage must be gradually increased from zero to testing value and then gradually decreased for shut down. When timer is used, the power supply may be damaged by high impulse voltage generated during timer switch on and off.

Connect each terminal according to the circuit diagram shown below.

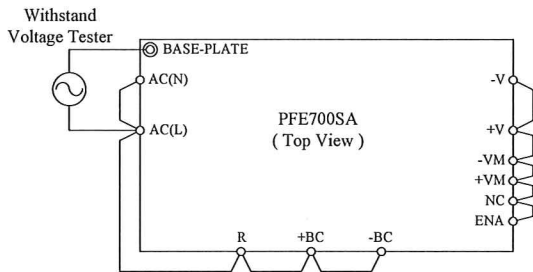

2.5kVAC 1 minute (20mA)

Fig.6-5

Input to Base-plate Withstand Voltage Test Method

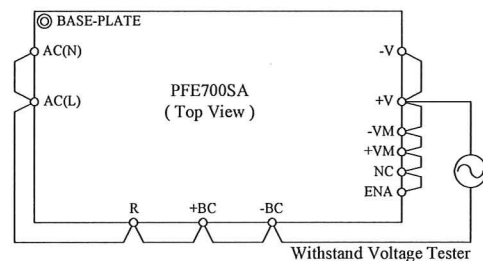

3kVAC 1 minute (20mA)

Fig.6-6

Input to Output Withstand Voltage Test Method

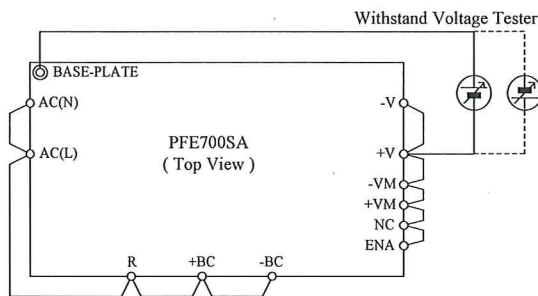

1.5kVDC 1 minute

Fig.6-7

Output to Base-plate Withstand Voltage Test Method

### Withstand Voltage Testing with External Application

The above Withstand Voltage Testing specification applies only to power module as stand-alone unit. Please take note of the following points when Withstand Voltage Testing is performed with attached external application. For connections shown in Fig. 5-1, when injecting 3kVAC between Input – Output, Voltage Divider Ratio between Input – Base-plate and Output – Base-plate will be affected by capacitance value ratio connected between the Input – Base-plate and Output – Base-plate. When selecting external capacitor at the Input – Base-plate and Output – Base-plate, take care of the capacitance value and voltage rating.

Capacitor of Input – Base-plate : (C2,C3,C6,C7,C14)

Capacitor of Output – Base-plate : (C12,C13)

## 7. Mounting Method

### 7-1. Mounting Method

These products can be used in any orientation but be sure to consider enough airflow to avoid heat accumulation around the power supply. Consider surrounding components layout and set the PCB mounting direction such that air can flow through the heat sink by forced or convection cooling. Refer to the power module application note "Power module mounting method" for mounting method on PWB. This product can operate at actual mounting condition when Base-plate temperature and ambient temperature are maintained at below the 100°C. For details, refer to “Derating Curve Fig.7-3 and Fig.7-4”.

Temperature at worst case operating condition at the measuring point is shown in Fig.7-1 and Fig.7-2. For Thermal Design details, refer to Application Notes “Thermal Design” section.

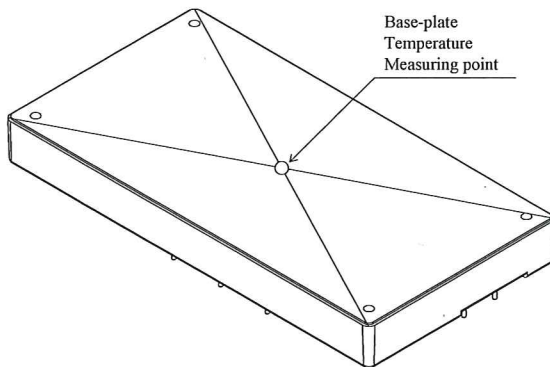

Fig.7-1 Base-plate Temperature Measuring Point

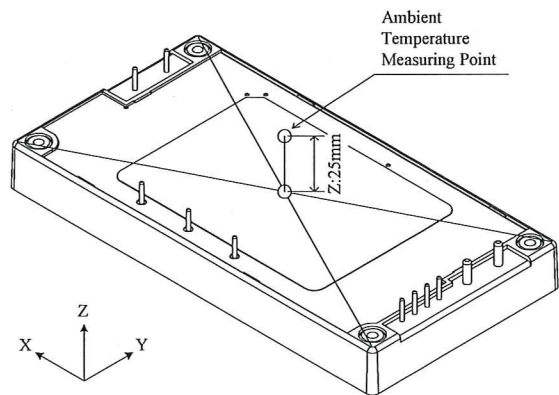

Fig.7-2 Ambient Temperature Measuring Point

### 7-2. Output Derating

Operating temperature range is limited according to Fig.7-3 and Fig.7-4.

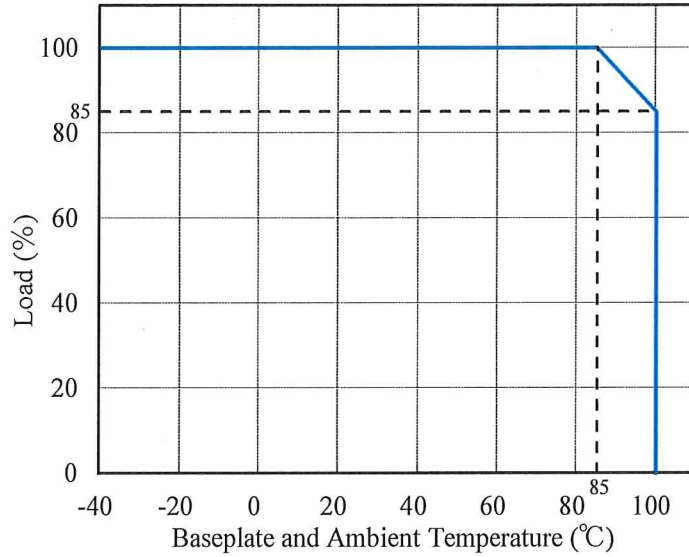

Fig.7-3 Derating Curve  
(Load v.s. Baseplate and Ambient Temperature)

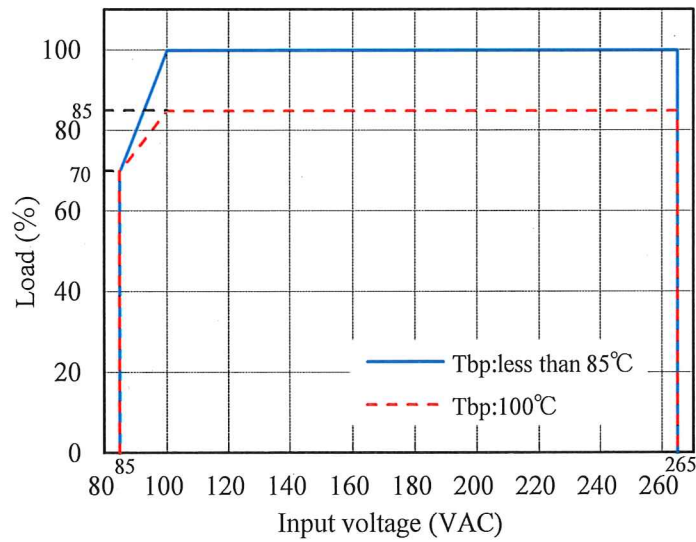

Fig.7-4 Derating Curve  
(Load v.s. Input voltage)

To further improve the reliability, it is recommended to use this power supply with Base-plate and ambient temperature derating.

### 7-3. Notes on Designing PWB for Power Module Mounting

In order to satisfy withstand voltage specification, it is recommended to keep following distances for each pattern wiring and mounting components distance of primary circuit (Input), secondary circuit (Output) and FG (Base-plate).

Between primary circuit and FG . . . . . 5.0mm or more

Between secondary circuit and FG . . . . . 2.0mm or more

To ensure conformance to various safety standards, creepage distance and clearance between the primary and the secondary of the PWB for power module mounting shall be considered. From the power module cover outline and terminals, keep creepage distance and clearance between the primary and the secondary.

In order to acquire safety standards for this power module, creepage distance and clearance between the primary and the secondary is designed to be 7.5 mm. The pattern wiring prohibited area of the PWB is shown in Fig. 7-5, and power module cover outline is shown in Fig. 7-6.

Creepage distance and clearance between the primary and the secondary of the PWB for power module mounting varies depending on power module mounting condition, contact our customer support for details.

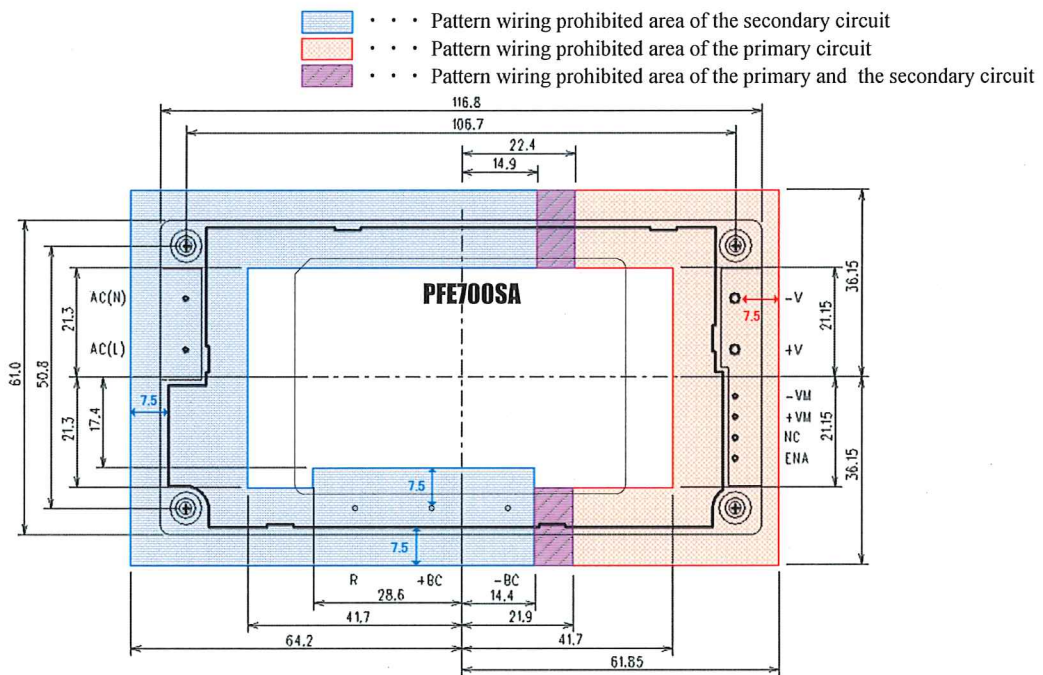

Fig.7-5 Pattern wiring prohibited area of PWB for power module mounting  
(When the distance on the primary and the secondary is 7.5 mm)

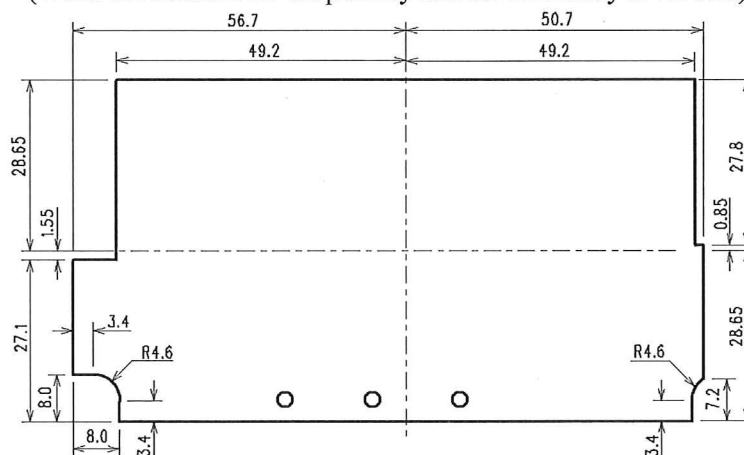

Fig.7-6 Dimensions of the power supply cover



#### 7-4. Recommended Soldering Condition

Recommended soldering temperature is as follows.

- Soldering Dip : 260°C, within 10 seconds
- Preheat : 130°C, within 60 seconds

#### 7-5. Recommended washing Condition

After soldering, following washing condition is recommended.

For other washing conditions, consult our Customer Support Group.

- (1) Recommended washing solution
  - IPA (Isopropyl Alcohol)

- (2) Washing method

In order to avoid penetration inside the power module, washing should be done with brush.  
Then, dry up thoroughly after washing.

### 8. Before Concluding Power Module Damage

Verify following items before concluding power module damage.

- (1) No output voltage

- Is specified input voltage applied?
- Is there no abnormality with the output load?
- Is the actual baseplate temperature within the specified operating temperature of this module?

- (2) Output voltage is low

- Is specified input voltage applied?
- Is there no abnormality with the output load?

- (3) Load regulation or line regulation is large

- Is specified input voltage applied?
- Are the input or output terminals firmly connected?
- Are the input and output wires too thin?

- (4) Large output ripple

- Is the measurement done according to methods described in the Instruction Manual or is it an equivalent method?

### 9. Warranty Period

Warranty period is 5 years.

For damages occurring at normal operation within this warranty period, repair is free of charge.

Following cases are not covered by warranty

- (1) Improper usage like dropping products, applying shock and defects from operation exceeding specification of the unit.
- (2) Defects resulting from natural disaster (fire, flood etc.)
- (3) Unauthorized modifications or repair by the buyers' defects not cause by our company.